

American Legend WHEELS



CRUISER

RACER

STREETER

SPRINTER

Being rebellious is all about showing that desire to resist authority, control and convention. It's thumping V8s, burning rubber and rock music. It's the ultimate expression of personal freedom in a world of endless rules and regulations for those who enjoy classic muscle cars, love what they stand for and the way of life that era represents. It's about styling, substance and attitude that only vehicles with a muscular persona and cool heritage can deliver.

WHAT'S IN THE NAMES?

American car culture was born on the Saturday night cruise route, local drive-in, small town drag strips and dry lake beds across the country. With names like CRUISER, STREETER, SPRINTER and RACER, American Legend's 1-piece **CLASSIC MUSCLE SERIES** wheels reflect this enduring legacy.

STYLING: Modern edge on classic designs, with a signature deep dish and smooth lip look.

FITMENT: Specific offsets and backspacing for that muscular stance on your American classic.

FINISH: Precision crafted finishes and unsurpassed quality that must be seen in-the-flesh to be appreciated.



#STAYREBELLIOUS

AS SEEN ON:



1955 CHEVY BEL AIR
RACER - GREY
FR: 18" X 7" - 225/40 R18
RR: 18" X 9" - 275/35 R18

VISUALIZER

SEE HOW THEY LOOK ON YOUR CAR



SCAN QR CODE
ON MOBILE
DEVICE OR
VIEW ONLINE



ALW_12-19

AMERICANLEGENDWHEELS.COM

Visit our website for more finish options, information, galleries and to see how our wheels look on your car with our unique VISUALIZER tool!



PROJECT SPEC'S
1967 PONTIAC GTO
SPRINTER / GLOSS

| | WHEEL SIZE (IN) | TIRE SIZE | SUSPENSION |
|-----|-----------------|------------|------------|
| FR: | 18 X 8 | 235/40 R18 | 1.5" DROP |
| RR: | 18 X 8 | 265/35 R18 | 1.5" DROP |

#STAYREBELLIOUS

The late '60's to the early '70's was the glory years of the muscle car era. Manufacturers slugged it out with crazy colors, wild styling, screaming engines and muscle-bound wheels. American Legend's **SPRINTER** captures all this power 'n' passion and merges it into a truly timeless design. Featuring a machined wheel face and lip with inner wheel spokes accented in black. Center cap included – Upgraded center caps also available.



SPRINTER CAP INCLUDED



GLOSS CLEAR / BLACK



Mustang

Wheel Caps

Upgrade your new wheels with custom Mustang center caps.



| PART # | DESCRIPTION | RETAIL |
|---------|-------------------|---------|
| SPRMCAP | Mustang Cap, each | \$39.00 |

| PART # | FINISH | SIZE | BOLT PATTERN | BACK SPACE | FRONT SPACE | RETAIL/EACH |
|--------------|---------------|------|--------------|------------|-------------|-------------|
| ALS177006PBM | Gloss / Black | 17x7 | 5x4 | 4.25" * | 3.75" | \$180.00 |
| ALS177006PBF | Gloss / Black | 17x7 | 5x4.5 | 4.25" * | 3.75" | \$180.00 |
| ALS177006PBC | Gloss / Black | 17x7 | 5x4.75 | 4.25" * | 3.75" | \$180.00 |
| ALS177006PBT | Gloss / Black | 17x7 | 5x5 | 4.25" * | 3.75" | \$180.00 |
| ALS178000PBM | Gloss / Black | 17x8 | 5x4 | 4.5" | 4.5" | \$185.00 |
| ALS178006PBF | Gloss / Black | 17x8 | 5x4.5 | 4.75" * | 4.25" | \$185.00 |
| ALS178000PBC | Gloss / Black | 17x8 | 5x4.75 | 4.5" | 4.5" | \$185.00 |
| ALS178000PBT | Gloss / Black | 17x8 | 5x5 | 4.5" | 4.5" | \$185.00 |
| ALS187006PBM | Gloss / Black | 18x7 | 5x4 | 4.25" * | 3.75" | \$203.00 |
| ALS187006PBF | Gloss / Black | 18x7 | 5x4.5 | 4.25" * | 3.75" | \$203.00 |
| ALS187006PBC | Gloss / Black | 18x7 | 5x4.75 | 4.25" * | 3.75" | \$203.00 |
| ALS187006PBT | Gloss / Black | 18x7 | 5x5 | 4.25" * | 3.75" | \$203.00 |
| ALS18800PBM | Gloss / Black | 18x8 | 5x4 | 4.5" | 4.5" | \$207.00 |
| ALS188006PBF | Gloss / Black | 18x8 | 5x4.5 | 4.75" * | 4.25" | \$207.00 |
| ALS188000PBC | Gloss / Black | 18x8 | 5x4.75 | 4.5" | 4.5" | \$207.00 |
| ALS188000PBT | Gloss / Black | 18x8 | 5x5 | 4.5" | 4.5" | \$207.00 |



American Legend **CRUISER** is the ultimate finishing touch for your street rod or custom. By combining original styling cues with a new millennia twist, it just looks right. No wonder it's a favorite! Features 10 bolt holes to accommodate 2 different bolt patterns. Includes flat wheel cap. Upgraded center caps also available.

PROJECT SPECS
1985 CHEVY C10
CRUISER / SILVER

| WHEEL SIZE (IN) | TIRE SIZE | SUSPENSION |
|-----------------|------------|------------|
| FR: 18 X 8 | 255/55 R18 | LOWERED |
| RR: 20 X 10 | 275/45 R20 | LOWERED |

CHROME CAP INCLUDED
 (SHOWN WITH CUSTOM STRIPING)

| PART # | FINISH | SIZE | BOLT PATTERN | BACK SPACE | FRONT SPACE | RETAIL/EACH |
|--------------|----------|--------|-----------------------|------------|-------------|-------------|
| AC177006PPC | Polished | 17x7 | 10-hole (5x4.75, 5x5) | 4.25" * | 3.75" | \$180.00 |
| AC178000PPC | Polished | 17x8 | 10-hole (5x4.75, 5x5) | 4.5" | 4.5" | \$185.00 |
| AC187006PPC | Polished | 18x7 | 10-hole (5x4.75, 5x5) | 4.25" * | 3.75" | \$203.00 |
| AC188000PPDC | Polished | 18x8 | 10-hole (5x4.75, 5x5) | 4.5" | 4.5" | \$207.00 |
| AC189006PPDC | Polished | 18x9 | 10-hole (5x4.75, 5x5) | 5.25" * | 4.75" | \$216.00 |
| AC208512PPC | Polished | 20x8.5 | 10-hole (5x4.75, 5x5) | 5.25" ** | 4.25" | \$300.00 |
| AC201000PPC | Polished | 20x10 | 10-hole (5x4.75, 5x5) | 5.5" | 5.5" | \$284.00 |
| AC177006PSC | Silver | 17x7 | 10-hole (5x4.75, 5x5) | 4.25" * | 3.75" | \$180.00 |
| AC178000PSC | Silver | 17x8 | 10-hole (5x4.75, 5x5) | 4.5" | 4.5" | \$185.00 |
| AC187006PSC | Silver | 18x7 | 10-hole (5x4.75, 5x5) | 4.25" * | 3.75" | \$203.00 |
| AC188000PSDC | Silver | 18x8 | 10-hole (5x4.75, 5x5) | 4.5" | 4.5" | \$207.00 |
| AC189006PSDC | Silver | 18x9 | 10-hole (5x4.75, 5x5) | 5.25" * | 4.75" | \$216.00 |
| AC208512PSC | Silver | 20x8.5 | 10-hole (5x4.75, 5x5) | 5.25" ** | 4.25" | \$300.00 |
| AC201000PSC | Silver | 20x10 | 10-hole (5x4.75, 5x5) | 5.5" | 5.5" | \$284.00 |
| AC177006PCC | Chrome | 17x7 | 10-hole (5x4.75, 5x5) | 4.25" * | 3.75" | \$280.00 |
| AC188000PCDC | Chrome | 18x8 | 10-hole (5x4.75, 5x5) | 4.5" | 4.5" | \$305.00 |
| AC189006PCDC | Chrome | 18x9 | 10-hole (5x4.75, 5x5) | 5.25" * | 4.75" | \$316.00 |
| AC208512PCC | Chrome | 20x8.5 | 10-hole (5x4.75, 5x5) | 5.25" ** | 4.25" | \$390.00 |
| AC201000PCC | Chrome | 20x10 | 10-hole (5x4.75, 5x5) | 5.5" | 5.5" | \$400.00 |



POLISHED



SILVER
W/ MACHINED LIP



CHROME

* Wheel Offset - * = 6+, ** = 12+

WHEEL CAPS & ACCESSORIES

Rally Wheel Cap upgrades, replacement Wheel Caps, Lug nuts and Accessories also available. For options, details and more: **SEE PAGE 8**



CAP1002C



CAP1000C



WK1012



WK1013



WK1012C

American Legend **RACER** has a nostalgic design inspired by those post-war speed junkies who quenched their need for speed by hurtling across the endless expanses of Bonneville, El Mirage and Black Rock. American Legend's modern incarnation is old-school cool, looking equally at home on a traditional Jalopy as it does on a modern-day fairgrounds brawler. Includes chrome center cap.

#STAYREBELLIOUS



GREY
W/ MACHINED LIP



STCCAP

SCREW &
WRENCH SET

| PART # | FINISH | SIZE | BOLT PATTERN | BACK SPACE | FRONT SPACE | RETAIL/EACH |
|--------------|--------|------|--------------|------------|-------------|-------------|
| ALR177006PGM | Grey | 17x7 | 5x4 | 4.25" * | 3.75" | \$180.00 |
| ALR177006PGF | Grey | 17x7 | 5x4.5 | 4.25" * | 3.75" | \$180.00 |
| ALR177006PGC | Grey | 17x7 | 5x4.75 | 4.25" * | 3.75" | \$180.00 |
| ALR177006PGT | Grey | 17x7 | 5x5 | 4.25" * | 3.75" | \$180.00 |
| ALR178000PGM | Grey | 17x8 | 5x4 | 4.5" | 4.5" | \$185.00 |
| ALR178006PGF | Grey | 17x8 | 5x4.5 | 4.75" * | 4.25" | \$185.00 |
| ALR178000PGC | Grey | 17x8 | 5x4.75 | 4.5" | 4.5" | \$185.00 |
| ALR178000PGT | Grey | 17x8 | 5x5 | 4.5" | 4.5" | \$185.00 |
| ALR187006PGM | Grey | 18x7 | 5x4 | 4.25" * | 3.75" | \$203.00 |
| ALR187006PGF | Grey | 18x7 | 5x4.5 | 4.25" * | 3.75" | \$203.00 |
| ALR187006PGC | Grey | 18x7 | 5x4.75 | 4.25" * | 3.75" | \$203.00 |
| ALR187006PGT | Grey | 18x7 | 5x5 | 4.25" * | 3.75" | \$203.00 |
| ALR188000PGM | Grey | 18x8 | 5x4 | 4.5" | 4.5" | \$207.00 |
| ALR188006PGF | Grey | 18x8 | 5x4.5 | 4.75" * | 4.25" | \$207.00 |
| ALR188000PGC | Grey | 18x8 | 5x4.75 | 4.5" | 4.5" | \$207.00 |
| ALR188000PGT | Grey | 18x8 | 5x5 | 4.5" | 4.5" | \$207.00 |
| ALR189006PGM | Grey | 18x9 | 5x4 | 5.25" * | 4.75" | \$216.00 |
| ALR189006PGF | Grey | 18x9 | 5x4.5 | 5.25" * | 4.75" | \$216.00 |
| ALR189006PGC | Grey | 18x9 | 5x4.75 | 5.25" * | 4.75" | \$216.00 |
| ALR189006PGT | Grey | 18x9 | 5x5 | 5.25" * | 4.75" | \$216.00 |





| PROJECT SPECS | | |
|--|------------|------------|
| 1957 CHEVY BEL AIR CONVERTIBLE RACER / GREY | | |
| WHEEL SIZE (IN) | TIRE SIZE | SUSPENSION |
| FR: 18 X 7 | 225/45 R18 | LOWERED |
| RR: 18 X 9 | 265/40 R18 | LOWERED |

CHROME CAP INCLUDED

| PART # | FINISH | SIZE | BOLT PATTERN | BACK SPACE | FRONT SPACE | RETAIL/EACH |
|--------------|----------|------|--------------|------------|-------------|-------------|
| ALR177006PPM | Polished | 17x7 | 5x4 | 4.25" * | 3.75" | \$180.00 |
| ALR177006PPF | Polished | 17x7 | 5x4.5 | 4.25" * | 3.75" | \$180.00 |
| ALR177006PPC | Polished | 17x7 | 5x4.75 | 4.25" * | 3.75" | \$180.00 |
| ALR177006PPT | Polished | 17x7 | 5x5 | 4.25" * | 3.75" | \$180.00 |
| ALR178000PPM | Polished | 17x8 | 5x4 | 4.5" | 4.5" | \$185.00 |
| ALR178006PPF | Polished | 17x8 | 5x4.5 | 4.75" * | 4.25" | \$185.00 |
| ALR178000PPC | Polished | 17x8 | 5x4.75 | 4.5" | 4.5" | \$185.00 |
| ALR178000PPT | Polished | 17x8 | 5x5 | 4.5" | 4.5" | \$185.00 |
| ALR187006PPM | Polished | 18x7 | 5x4 | 4.25" * | 3.75" | \$203.00 |
| ALR187006PPF | Polished | 18x7 | 5x4.5 | 4.25" * | 3.75" | \$203.00 |
| ALR187006PPC | Polished | 18x7 | 5x4.75 | 4.25" * | 3.75" | \$203.00 |
| ALR187006PPT | Polished | 18x7 | 5x5 | 4.25" * | 3.75" | \$203.00 |
| ALR188000PPM | Polished | 18x8 | 5x4 | 4.5" | 4.5" | \$207.00 |
| ALR188006PPF | Polished | 18x8 | 5x4.5 | 4.75" * | 4.25" | \$207.00 |
| ALR188000PPC | Polished | 18x8 | 5x4.75 | 4.5" | 4.5" | \$207.00 |
| ALR188000PPT | Polished | 18x8 | 5x5 | 4.5" | 4.5" | \$207.00 |
| ALR189006PPM | Polished | 18x9 | 5x4 | 5.25" * | 4.75" | \$216.00 |
| ALR189006PPF | Polished | 18x9 | 5x4.5 | 5.25" * | 4.75" | \$216.00 |
| ALR189006PPC | Polished | 18x9 | 5x4.75 | 5.25" * | 4.75" | \$216.00 |
| ALR189006PPT | Polished | 18x9 | 5x5 | 5.25" * | 4.75" | \$216.00 |

* Wheel Offset - * = 6+, ** = 12+



POLISHED

American Legend's **STREETER** is the quintessential muscle car wheel. It's classic, yet fresh design takes the popular five-spoke configuration to a whole other level. Enabling it to look equally at home on a fastidious restoration, as it does on a full-house pro-touring machine. A wheel for all ages, which will never grow old. Polished center cap included.



POLISHED CAP INCLUDED



POLISHED



| PART # | FINISH | SIZE | BOLT PATTERN | BACK SPACE | FRONT SPACE | RETAIL/EACH |
|-------------|----------|------|--------------|------------|-------------|-------------|
| S1177006PPM | Polished | 17x7 | 5x4 | 4.25" * | 3.75" | \$180.00 |
| S1177006PPF | Polished | 17x7 | 5x4.5 | 4.25" * | 3.75" | \$180.00 |
| S1177006PPC | Polished | 17x7 | 5x4.75 | 4.25" * | 3.75" | \$180.00 |
| S1177006PPT | Polished | 17x7 | 5x5 | 4.25" * | 3.75" | \$180.00 |
| S1178000PPM | Polished | 17x8 | 5x4 | 4.5" | 4.5" | \$185.00 |
| S1178000PPF | Polished | 17x8 | 5x4.5 | 4.5" | 4.5" | \$185.00 |
| S1178006PPF | Polished | 17x8 | 5x4.5 | 4.75" * | 4.25" | \$185.00 |
| S1178000PPC | Polished | 17x8 | 5x4.75 | 4.5" | 4.5" | \$185.00 |
| S1178000PPT | Polished | 17x8 | 5x5 | 4.5" | 4.5" | \$185.00 |
| S1187006PPM | Polished | 18x7 | 5x4 | 4.75" * | 4.25" | \$185.00 |
| S1187006PPF | Polished | 18x7 | 5x4.5 | 4.75" * | 4.25" | \$185.00 |
| S1187006PPC | Polished | 18x7 | 5x4.75 | 4.75" * | 4.25" | \$185.00 |
| S1187006PPT | Polished | 18x7 | 5x5 | 4.75" * | 4.25" | \$185.00 |
| S1188000PPM | Polished | 18x8 | 5x4 | 4.5" | 4.5" | \$207.00 |
| S1188000PPF | Polished | 18x8 | 5x4.5 | 4.5" | 4.5" | \$207.00 |
| S1188006PPF | Polished | 18x8 | 5x4.5 | 4.75" * | 4.25" | \$207.00 |
| S1188000PPC | Polished | 18x8 | 5x4.75 | 4.5" | 4.5" | \$207.00 |
| S1188006PPC | Polished | 18x8 | 5x4.75 | 4.75" * | 4.25" | \$207.00 |
| S1188000PPT | Polished | 18x8 | 5x5 | 4.5" | 4.5" | \$207.00 |

* Wheel Offset - * = 6+, ** = 12+



PROJECT SPEC'S
1966 PONTIAC GTO
STREETEER / POLISHED

| | WHEEL SIZE (IN) | TIRE SIZE | SUSPENSION |
|-----|-----------------|------------|------------|
| FR: | 18 X 8 | 235/40 R18 | AIR RIDE |
| RR: | 18 X 9 | 265/40 R18 | AIR RIDE |

#STAYREBELLIOUS

| PART # | FINISH | SIZE | BOLT PATTERN | BACK SPACE | FRONT SPACE | RETAIL/EACH |
|-------------|----------|--------|--------------|------------|-------------|-------------|
| S1189006PPM | Polished | 18x9 | 5x4 | 5.25" * | 4.75" | \$216.00 |
| S1189006PPF | Polished | 18x9 | 5x4.5 | 5.25" * | 4.75" | \$216.00 |
| S1189006PPC | Polished | 18x9 | 5x4.75 | 5.25" * | 4.75" | \$216.00 |
| S1189006PPT | Polished | 18x9 | 5x5 | 5.25" * | 4.75" | \$216.00 |
| S1208512PPF | Polished | 20X8.5 | 5x4.5 | 5.25" ** | 4.25" | \$270.00 |
| S1208512PPC | Polished | 20X8.5 | 5x4.75 | 5.25" ** | 4.25" | \$270.00 |
| S1208512PPT | Polished | 20X8.5 | 5x5 | 5.25" ** | 4.25" | \$270.00 |
| S1201000PPF | Polished | 20x10 | 5x4.5 | 5.5" | 5.5" | \$284.00 |
| S1201000PPC | Polished | 20X10 | 5x4.75 | 5.5" | 5.5" | \$284.00 |
| S1201000PPT | Polished | 20X10 | 5x5 | 5.5" | 5.5" | \$284.00 |

COMING SOON!
POWERCOATED UPGRADE

SATIN BLACK POWDERCOAT

* Wheel Offset - * = 6+, ** = 12+

PROJECT SPEC'S
1967 CHEVY CHEVELLE
STREETEER / POLISHED

| | WHEEL SIZE (IN) | TIRE SIZE | SUSPENSION |
|-----|-----------------|------------|------------|
| FR: | 18 X 8 | 235/40 R18 | 1.5" DROP |
| RR: | 18 X 9 | 265/35 R18 | 2.5" DROP |



WHEEL CAPS & ACCESSORIES



CAP1002C



CAP1000C



WK1012



WK1013



WK10120



SPRCAP



SPRMCAP

WHEEL CAPS

| PART # | DESCRIPTION | STYLE / LOGO | MATERIAL | FINISH | QTY. | RETAIL |
|-------------------------|-----------------------|---|----------|----------|------|----------|
| CRUISER | | | | | | |
| CAP1002C | Cruiser Cap | No Logo | Metal | Chrome | EACH | \$29.00 |
| CAP1000C | Cruiser Cap | Chevy Bowtie | Metal | Chrome | EACH | \$39.00 |
| WK1012 | Rally Wheel Cap, Tall | Chevy Bowtie / Chevrolet Motor Division | Plastic | Chrome | EACH | \$50.00 |
| WK1012-4 | Rally Wheel Cap, Tall | Chevy Bowtie / Chevrolet Motor Division | Plastic | Chrome | 4 pc | \$180.00 |
| WK1013 | Rally Wheel Cap, Tall | No Logo | Plastic | Chrome | EACH | \$29.00 |
| WK1013-4 | Rally Wheel Cap, Tall | No Logo | Plastic | Chrome | 4 pc | \$110.00 |
| WK10120 | Rally Wheel Cap, Tall | Chevrolet Motor Division | Plastic | Chrome | EACH | \$50.00 |
| WK10120-4 | Rally Wheel Cap, Tall | Chevrolet Motor Division | Plastic | Chrome | 4 pc | \$180.00 |
| RACER / STREETER | | | | | | |
| STCCAP | Streeter / Racer Cap | No Logo | Metal | Chrome | EACH | \$29.00 |
| STPCAP | Streeter / Racer Cap | American Legend | Metal | Polished | EACH | \$39.00 |
| SPRINTER | | | | | | |
| SPRCAP | Sprinter Cap | American Legend | Plastic | Chrome | EACH | \$20.00 |
| SPRMCAP | Sprinter Cap | Mustang | Metal | Chrome | EACH | \$39.00 |



STCCAP



STPCAP

INCLUDED!



SCREW & WRENCH SET

#VSC (INSTALLED)



ACCESSORIES

| PART # | DESCRIPTION | MATERIAL | FINISH | RETAIL/EACH |
|--------------------|-------------|----------|--------|-------------|
| VALVE STEMS | | | | |
| VSC | Valve Stem | METAL | CHROME | \$1.50 |
| VSB | Valve Stem | RUBBER | BLACK | \$1.50 |

DEALER INFO

INTERESTED IN BECOMING A DEALER?

At American Legend Wheels, we understand the importance of forging long-lasting and beneficial partnerships. We also know that the products you choose to sell and the businesses you partner with are a big decision. That's why we give you the power of choice, with options that are flexible enough to work with your business.

Our pricing level programs offer different tier discounts depending on your type of business. We are opening these programs to wholesale distributors, retailers, independent garages, body shops and dealership parts departments. Becoming an American Legend Wheel dealer allows you to receive the following benefits:

- Consumer Referrals and Dealer Listing on American Legend Wheels Website
- Displays, Banners and Marketing Material
- Usage of Images for Websites and Printed Material
- Customized Shipments (drop shipping, LTL, shipping company of your choice)



**AMERICAN LEGEND WHEELS
USE 60° TAPERED SEAT / ACORN
STYLE LUG NUTS**

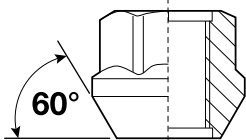

#901140



#371140



#371148S



#301173

**SPLINE LUGS
& ADAPTER
ALSO AVAILABLE**



#341140

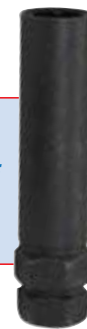

#11496-16BLK

LUG NUTS

| PART # | DESCRIPTION/ SEAT STYLE | LENGTH | HEX/SOCKET SIZE | THREAD | QTY / RETAIL | |
|--|----------------------------|--------|--------------------|------------|--------------|---------|
| | | | | | EACH | 5 PACK |
| OPEN END LUG NUTS - ZINC FINISH | | | | | | |
| 901140 | OE Bulge Acorn | .75" | 3/4" | 7/16-18 | \$2.00 | \$10.00 |
| 901142 | OE Bulge Acorn | .75" | 3/4" | 1/2-20 | \$2.00 | \$10.00 |
| 901145 | OE Bulge Acorn | .75" | 3/4" | 12mm x 1.5 | \$2.00 | \$10.00 |
| 901148 | OE Bulge Acorn | .75" | 3/4" | 14mm x 1.5 | \$2.00 | \$10.00 |
| CLOSED END LUG NUTS - CHROME FINISH | | | | | | |
| 371140 | Bulge Acorn | 1.5" | 3/4" | 7/16-18 | \$2.00 | \$10.00 |
| 371142 | Bulge Acorn | 1.5" | 3/4" | 1/2-20 | \$2.00 | \$10.00 |
| 371145 | Bulge Acorn | 1.5" | 3/4" | 12mm x 1.5 | \$2.00 | \$10.00 |
| 371148 | Bulge Acorn | 1.5" | 3/4" | 14mm x 1.5 | \$2.00 | \$10.00 |
| Coming Soon | Bulge Acorn | 1.75" | 3/4" | 7/16-18 | \$2.00 | \$10.00 |
| 301142S | Bulge Acorn | 1.75" | 3/4" | 1/2-20 | \$2.00 | \$10.00 |
| 301145S | Bulge Acorn | 1.75" | 3/4" | 12mm x 1.5 | \$2.00 | \$10.00 |
| 301148S | Bulge Acorn | 1.75" | 3/4" | 14mm x 1.5 | \$2.00 | \$10.00 |
| Coming Soon | Bulge Acorn | 2" | 3/4" | 7/16-18 | \$2.00 | \$10.00 |
| 701142B | Bulge Acorn | 2" | 3/4" | 1/2-20 | \$2.00 | \$10.00 |
| 701145B | Bulge Acorn | 2" | 3/4" | 12mm x 1.5 | \$2.00 | \$10.00 |
| 301173 | Bulge Acorn | 2" | 3/4" | 14mm x 2 | \$2.00 | \$10.00 |
| SPLINE LUG NUTS | | | | | | |
| 341140 | Spline, Chrome | 1.5" | 6 Spline | 7/16-18 | \$2.00 | \$10.00 |
| 11496-16BLK | Spline Adapter | 3.5" | Dual: 3/4", 13/16" | -- | \$2.00 | -- |



1955 CHEVY BEL AIR
18" X 7" RACER - GREY W/ PLAIN RACER CAP
#STCCAP & LUG NUTS INSTALLED



1970 CHEVY C10
18" X 9" CRUISER - POLISHED
W/ PLAIN CRUISER CAP #CAP1002C INSTALLED

ACCOUNT REQUIREMENTS:

We will require your business to provide the following:

1. Completed American Legend Wheels Dealer Account Application Form
2. A letter on company letterhead stating your desire to become a Dealer for American Legend Wheels
3. A copy of your federal or state business license and resellers permit
4. Provide storefront photo of your business ("virtual or online businesses" do not qualify) and marketing strategy (how you plan on selling our products)
5. Copies of a local or national advertisement
6. Meet initial buy-in amount

CONTACT OUR DEALER TEAM:



Toll Free: 855.924.3100



Fax Line: 714.276.9908



Email: info@americanlegendwheels.com



Mailing Address: 378 E. Orangethorpe Ave.
Placentia, CA 92870



VISUALIZER

With the help of our Visualizer, you can see just how good a set of American Legend Wheels will look on your car.

Either, pick from our huge archive of images by clicking, 'Year, Make, Model'. Or, upload a photo of your own car using the following simple steps;

1. Take a photo of your car (phone or camera) at a low, front 3/4 angle (See our video on choosing the best angle, plus other hints 'n' tips)
2. Transfer saved image to your desktop or laptop computer.
3. Click 'Add Photo' button on our Visualizer page, then either click to upload – or drag 'n' drop your image.
4. Once photo is uploaded, simply select the year, make, model, submodel and wheel size to ensure correct fitment.
5. Your car not in our archive? Not a problem! Just select the closest year, make, model, submodel – then substitute archive image by uploading your own image. Done!

GO TO VISUALIZER

**SCAN QR CODE
ON MOBILE DEVICE
OR VIEW ONLINE AT:**

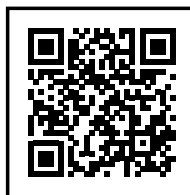

AMERICANLEGENDWHEELS.COM/VISUALIZER

SEE HOW OUR WHEELS LOOK ON YOUR CAR!

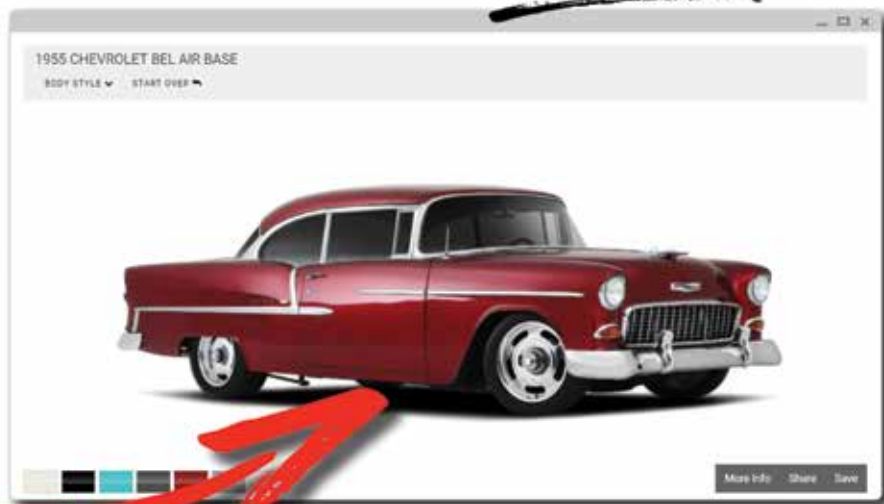

WHEEL & SUSPENSION MEASURING WORKSHEET

Determine the proper wheel & tire combination for your vehicle by using the worksheet below. A measuring tape, straight edge (such as a yard stick) and dial calipers are recommended for more accurate results.

| FRONT WHEEL SECTIONS | | | |
|----------------------|--|-------------|----------------|
| | | DRIVER SIDE | PASSENGER SIDE |
| A | Mounting surface to first obstruction frame side* | | |
| B | Mounting Surface to Inner Fender lip | | |
| C | Hub Diameter | | |
| D | "Brake Diameter: (Center of hub to top of caliper/drum x 2)" | | |
| E | Protrusion of caliper past mounting surface | | |
| F | Hub Length | | |
| G | Fender Height from center of hub | | |
| H | Wheel Well Height from center of hub | | |

*first obstruction that wheel & tire may come in contact

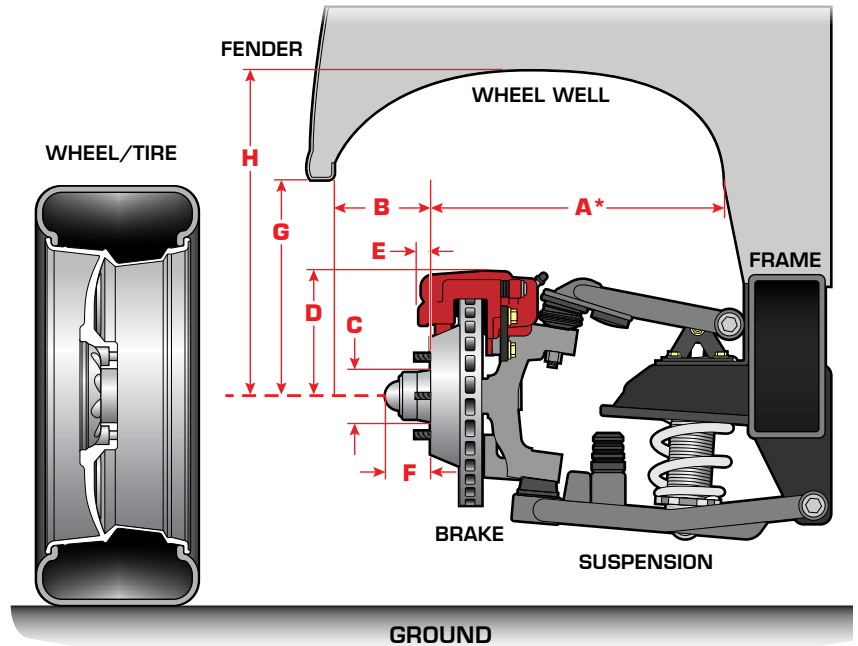

| REAR WHEEL SECTIONS | | | |
|---------------------|--|-------------|----------------|
| | | DRIVER SIDE | PASSENGER SIDE |
| A | Mounting surface to first obstruction frame side* | | |
| B | Mounting Surface to Inner Fender lip | | |
| C | Hub Diameter | | |
| D | "Brake Diameter: (Center of hub to top of caliper/drum x 2)" | | |
| E | Protrusion of caliper past mounting surface | | |
| F | Fender Height from center of hub | | |
| G | Wheel Well Height from center of hub | | |

*first obstruction that wheel & tire may come in contact

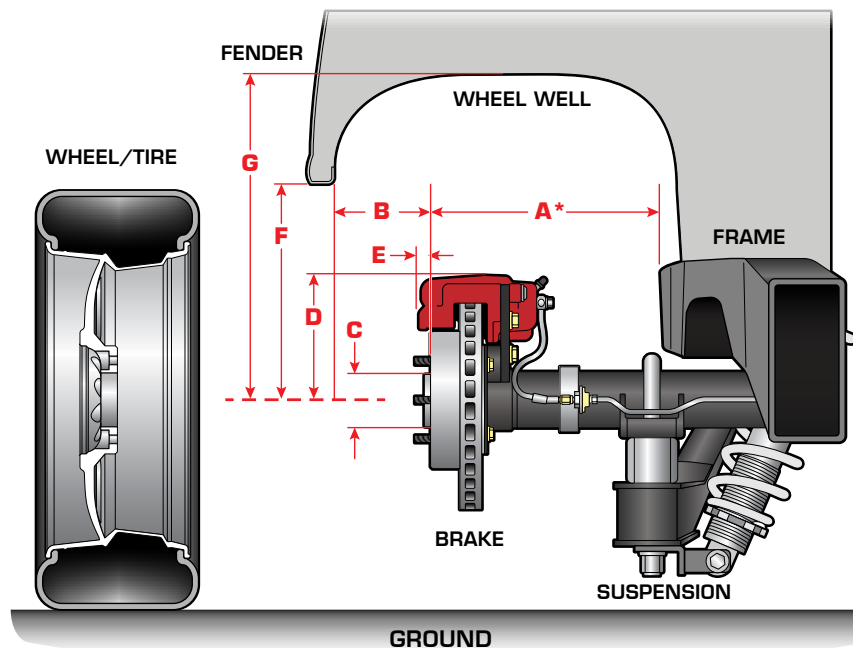

| ADDITIONAL VEHICLE INFO | | |
|---------------------------------------|-------|------|
| | FRONT | REAR |
| BOLT PATTERN (BOLT # X DIAMETER) | | |
| WHEEL STUD LENGTH | | |
| BRAKE SYSTEM & DIA. (DISC OR DRUM) | | |
| CURRENT WHEEL SIZE (DIAMETER X WIDTH) | | |
| WHEEL BACK SPACE | | |
| CURRENT TIRE SIZE | | |

NOTES

NOTE: Wheel fitments derived from this form are based on your measurements and are strictly suggested sizes. It is crucial that you review all fitment information before ordering your wheels. American Legend Wheels is not responsible for errors in special fitments.

WHEEL FITMENT GUIDE

WHEEL WIDTH, DIAMETER, & BACKSPACE

Wheel width is the distance, in inches, measured from bead seat to bead seat across the barrel of the wheel. Wheel width is used to determine compatible tire sizes and directly affects a tire's contact patch with the ground. Depending on the width of the wheel, it will either enlarge or shrink your tire's contact patch, leading to changes in your vehicle's handling characteristics. The "overall wheel width" is used to determine the wheel backspace and front space measurements.

Wheel diameter is the distance, measured in inches, across the face of the wheel, from bead seat to bead seat and is used to determine compatible tire sizes. Only wheels and tires of the same diameter can be safely mounted and paired together along the same axle. As little as a half-inch difference in diameter can lead to unsafe and undesired results. The overall wheel diameter can vary depending on the wheel design and affect clearance.

Backspace is the measured distance from the wheel's mounting surface to the very back edge of the overall wheel width (not the inner bead face) and is often incorrectly referred to as offset (see Wheel Offsets). This measurement is important when identifying inner wheel clearance closest to the vehicle's frame and suspension components. Although related, backspace should not be confused with offset.

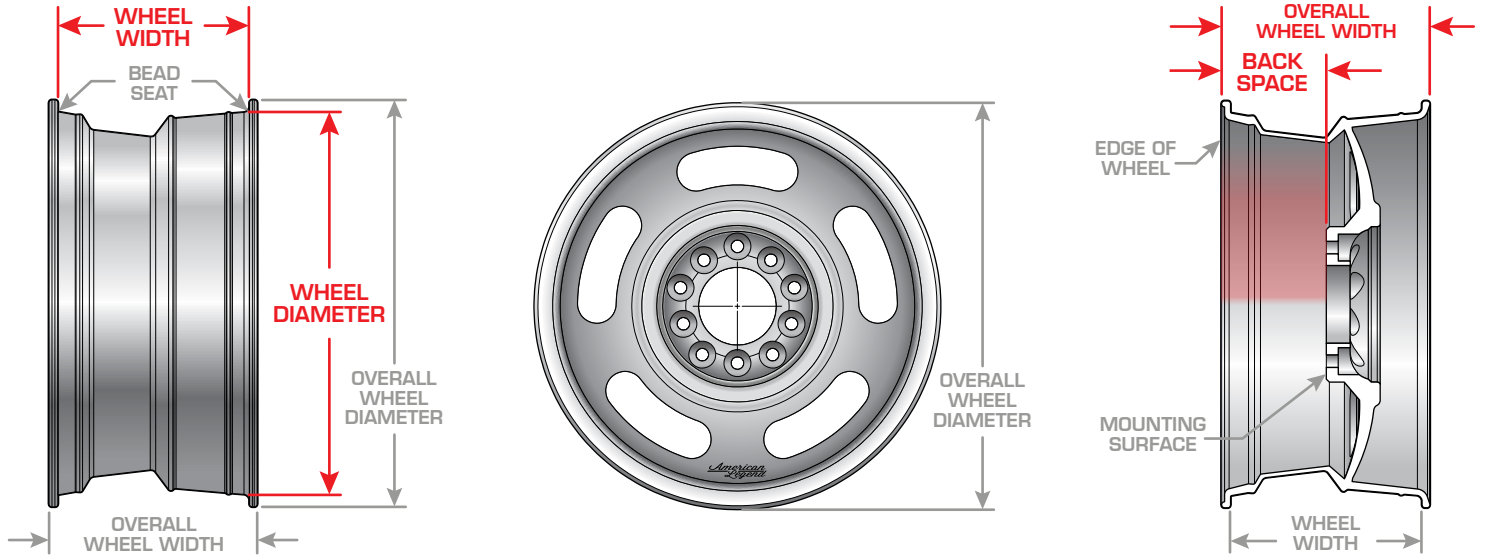

TIRE SIZES

TIRE SIZE CODE

Markings on the tire sidewall identifying standardized tire specifications and performance ratings. These include the vehicle class (P=Passenger Car, LT=Light Truck), section width (mm), aspect ratio (%), maximum speed rating, construction (R=Radial) and wheel diameter (inch).

SECTION WIDTH

The overall distance in millimeters measured from sidewall-to-sidewall of the tire when inflated – and not under load. Always wider than the tread width, although natural flex in the tire can allow the overall tire width to change depending on the wheel width it's being mounted to. Section width is labeled as the first number on the tire size code.

TREAD WIDTH

The distance between the two outer edges of a tire's tread. This is the tire's shoulder-to-shoulder width and is the section of tire that contacts the road surface.

ASPECT RATIO

The percentage of a tire's sidewall height to its section width (i.e. the 45 in 275/45 ZR18 indicates the height of the tire's sidewall is 45% of its section width.) This distance is measured from the top of the tire tread to the bottom of the tire bead. Also referred to as a tire's profile or series.

RECOMMENDED TIRE SECTION WIDTHS (MM)

| WHEEL WIDTH (IN.) | MINIMUM | IDEAL | MAXIMUM |
|-------------------|---------|------------|---------|
| 7.0" | 195 | 205 or 215 | 225 |
| 8.0" | 215 | 225 or 235 | 245 |
| 8.5" | 225 | 235 or 245 | 255 |
| 9.0" | 235 | 245 or 255 | 265 |
| 10.0" | 255 | 265 or 275 | 285 |

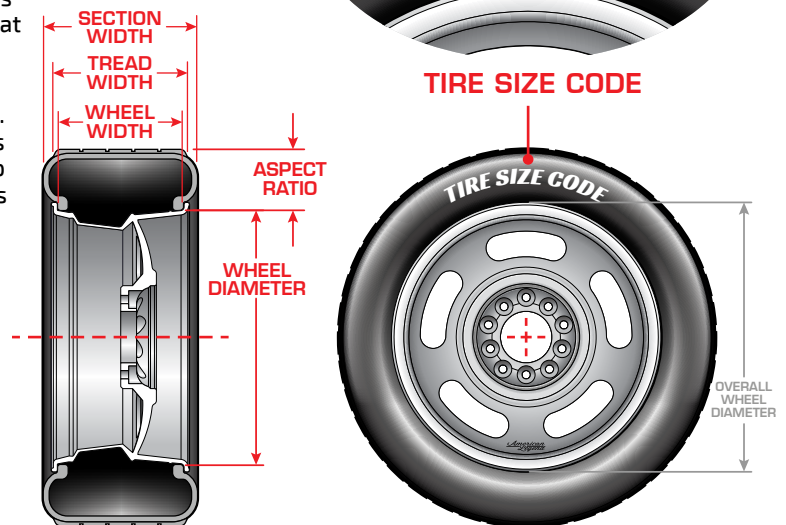
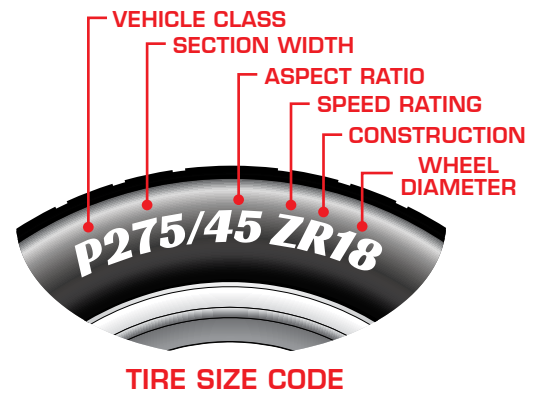

WHEEL OFFSETS

Wheel **offset** is the distance measured in millimeters from the wheel's centerline and the mounting surface of the wheel. Having the right offset is essential to proper wheel fitment. The offset distance determines where the tire and wheel assembly sit in relation to suspension components and the vehicle fenders. There are different types of offsets **negative**, **zero**, and **positive**. We offer specific offsets and backspacing for that muscular stance on your American classic.

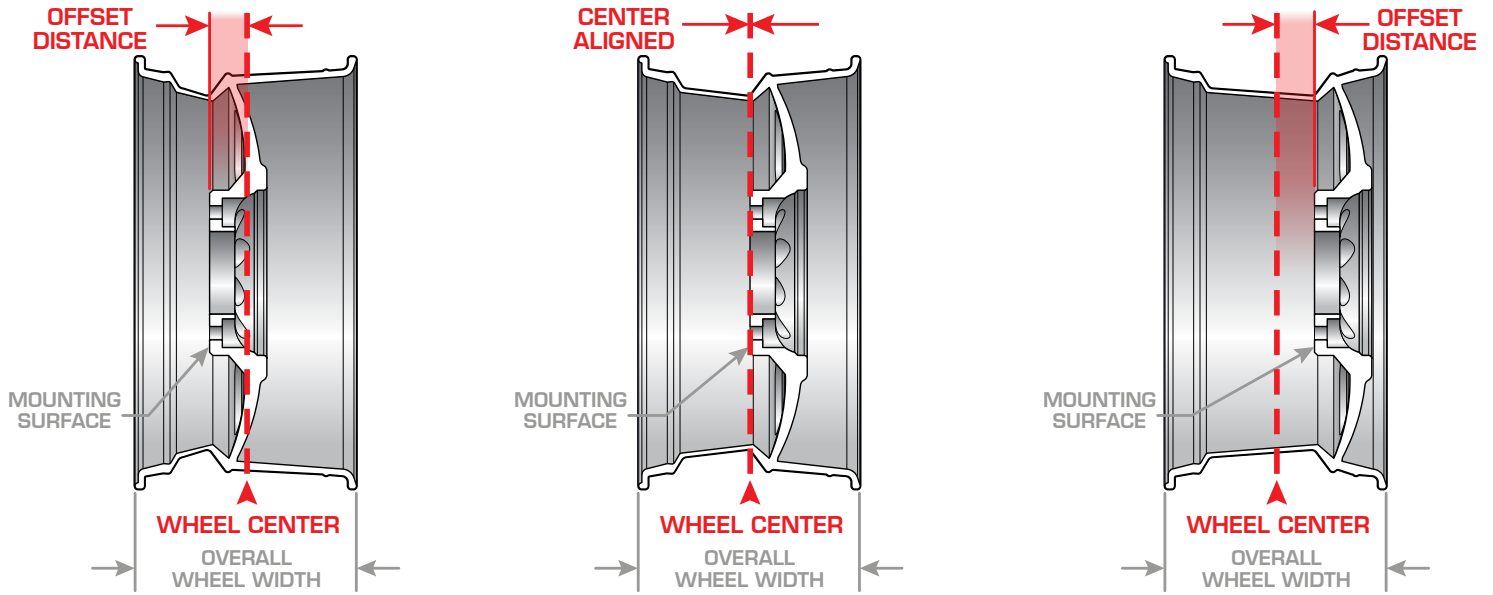

NEGATIVE OFFSET

The mounting surface is positioned before the wheel's centerline, closer to the back of the wheel and the vehicles suspension.

ZERO OFFSET

The mounting surface position is aligned with the wheel's centerline. Back space and front space measurements will have equal dimensions.

POSITIVE OFFSET

The mounting surface is positioned past the wheel's centerline, closer to the face of the wheel. This layout commonly results in a higher backspace measurement.

OFFSET / BACKSPACE CONVERSION CHART

American Legend OFFSET/BACKSPACE CONVERSION CHART

OFFSET (mm) TO BACKSPACE (inches) / 25.4 mm = 1 inch

| WHEEL WIDTH | BACKSPACE | | | | | | | | | | | | | | | | | | | | | | | | | | |
|-------------|-----------|-------|-------|-------|-------|-------|-------|-------|-------|-------|-------|-------|-------|-------|-------|-------|-------|-------|-------|-------|-------|-------|-------|-------|-------|-------|--|
| | 3.25" | 3.50" | 3.75" | 4.00" | 4.25" | 4.50" | 4.75" | 5.00" | 5.25" | 5.50" | 5.75" | 6.00" | 6.25" | 6.50" | 6.75" | 7.00" | 7.25" | 7.50" | 7.75" | 8.00" | 8.25" | 8.50" | 8.75" | 9.00" | 9.25" | 9.50" | |
| 5" | 6 | 12 | 19 | 25 | 32 | 38 | 44 | 51 | 57 | 63 | 69 | 76 | | | | | | | | | | | | | | | |
| 5.5" | 0 | 6 | 12 | 19 | 25 | 32 | 38 | 44 | 51 | 57 | 62 | 69 | 76 | | | | | | | | | | | | | | |
| 6" | -6 | 0 | 6 | 12 | 19 | 25 | 32 | 38 | 44 | 51 | 57 | 62 | 69 | 76 | | | | | | | | | | | | | |
| 6.5" | -12 | -6 | 0 | 6 | 12 | 19 | 25 | 32 | 38 | 44 | 51 | 57 | 62 | 69 | 76 | | | | | | | | | | | | |
| 7" | -19 | -12 | -6 | 0 | 6 | 12 | 19 | 25 | 32 | 38 | 41 | 51 | 57 | 62 | 69 | 76 | | | | | | | | | | | |
| 7.5" | -25 | -19 | -12 | -6 | 0 | 6 | 12 | 19 | 25 | 32 | 38 | 41 | 51 | 57 | 62 | 69 | 76 | | | | | | | | | | |
| 8" | -32 | -25 | -19 | -12 | -6 | 0 | 6 | 12 | 19 | 25 | 32 | 38 | 41 | 51 | 57 | 62 | 69 | 76 | | | | | | | | | |
| 8.5" | -38 | -32 | -25 | -19 | -12 | -6 | 0 | 6 | 12 | 19 | 25 | 32 | 38 | 41 | 51 | 57 | 62 | 69 | 76 | | | | | | | | |
| 9" | -44 | -38 | -32 | -25 | -19 | -12 | -6 | 0 | 6 | 12 | 19 | 25 | 32 | 38 | 41 | 51 | 57 | 62 | 69 | 76 | | | | | | | |
| 9.5" | -51 | -44 | -38 | -32 | -25 | -19 | -12 | -6 | 0 | 6 | 12 | 19 | 25 | 32 | 38 | 41 | 51 | 57 | 62 | 69 | 76 | | | | | | |
| 10" | -57 | -51 | -44 | -38 | -32 | -25 | -19 | -12 | -6 | 0 | 6 | 12 | 19 | 25 | 32 | 38 | 41 | 51 | 57 | 62 | 69 | 76 | | | | | |
| 10.5" | -63 | -57 | -51 | -44 | -38 | -32 | -25 | -19 | -12 | -6 | 0 | 6 | 12 | 19 | 25 | 32 | 38 | 41 | 51 | 57 | 62 | 69 | 76 | | | | |
| 11" | -69 | -63 | -57 | -51 | -44 | -38 | -32 | -25 | -19 | -12 | -6 | 0 | 6 | 12 | 19 | 25 | 32 | 38 | 41 | 51 | 57 | 62 | 69 | 76 | | | |
| 11.5" | -75 | -69 | -63 | -57 | -51 | -44 | -38 | -32 | -25 | -19 | -12 | -6 | 0 | 6 | 12 | 19 | 25 | 32 | 38 | 41 | 51 | 57 | 62 | 69 | 76 | | |
| 12" | -81 | -75 | -69 | -63 | -57 | -51 | -44 | -38 | -32 | -25 | -19 | -12 | -6 | 0 | 6 | 12 | 19 | 25 | 32 | 38 | 41 | 51 | 57 | 62 | 69 | 76 | |
| 12.5" | -87 | -81 | -75 | -69 | -63 | -57 | -51 | -44 | -38 | -32 | -25 | -19 | -12 | -6 | 0 | 6 | 12 | 19 | 25 | 32 | 38 | 41 | 51 | 57 | 62 | 69 | |
| 13" | -93 | -87 | -81 | -75 | -69 | -63 | -57 | -51 | -44 | -38 | -32 | -25 | -19 | -12 | -6 | 0 | 6 | 12 | 19 | 25 | 32 | 38 | 41 | 51 | 57 | 62 | |
| | 3.25" | 3.50" | 3.75" | 4.00" | 4.25" | 4.50" | 4.75" | 5.00" | 5.25" | 5.50" | 5.75" | 6.00" | 6.25" | 6.50" | 6.75" | 7.00" | 7.25" | 7.50" | 7.75" | 8.00" | 8.25" | 8.50" | 8.75" | 9.00" | 9.25" | 9.50" | |

WHEEL FITMENT GUIDE

WHEEL BOLT PATTERNS

Bolt patterns are also referred to as stud pattern, bolt circle, or PCD (Pitch Circle Diameter). The first number refers to the number of studs/bolt holes, while the second number is the diameter of the imaginary circle that passes through the center of each stud (or bolt hole). Generally stated as 5 on 4 1/2, or 5x4 3/4 – metric equivalents include 5x114.3 and 5x120.65. Some wheels have more than one set of bolt holes such as **dual pattern** wheels (total of 10 holes), which allows the same wheel to be fitted to vehicles with a different bolt pattern or PCD.

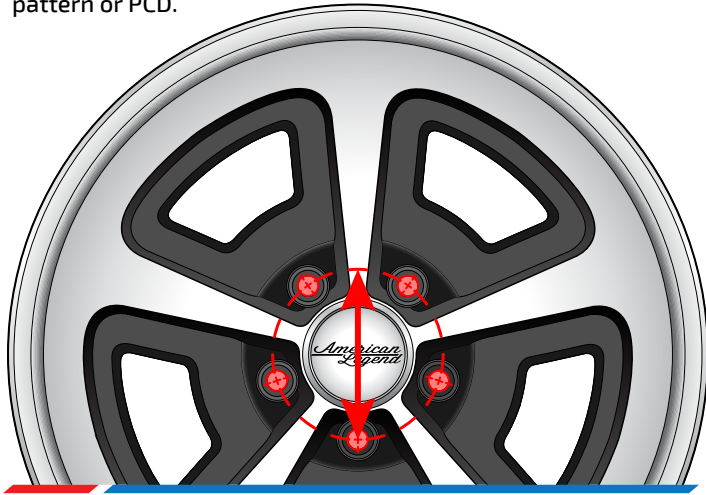

5-LUG PATTERN

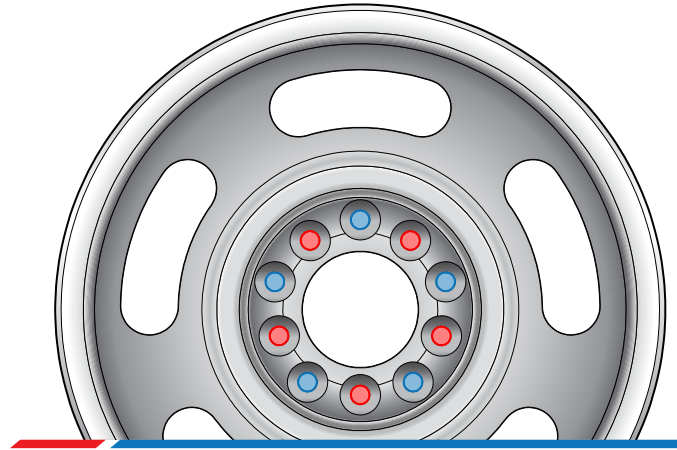

DUAL PATTERN 5-LUG (10 HOLE)

5-lug bolt patterns can be difficult to measure since the bolt holes are not positioned directly across from each other. You can estimate the measurement by using a straight line from the backside of one hole to the center of the third bolt hole. To accurately measure and identify your bolt pattern, use the American Legend Wheels **Bolt Pattern Template**.

| <i>American Legend</i> | | 5-LUG BOLT PATTERN CONVERSIONS (MM TO INCH) | | | | | | | | | | | | | |
|------------------------|------------|---|-------|-----|-------------|-----|-------|-----|------------|-----|-------|-----|------------|-----|-------|
| 5 x | 100 mm = | 5 x | 3.94" | 5 x | 112 mm = | 5 x | 4.41" | 5 x | 127 mm = | 5 x | 5.5" | 5 x | 150 mm = | 5 x | 5.91" |
| 5 x | 101.6 mm = | 5 x | 4" | 5 x | 114.3 mm = | 5 x | 4.5" | 5 x | 130 mm = | 5 x | 5.12" | 5 x | 155 mm = | 5 x | 6.1" |
| 5 x | 108 mm = | 5 x | 4.25" | 5 x | 115 mm = | 5 x | 4.52" | 5 x | 135 mm = | 5 x | 5.3" | 5 x | 165.1 mm = | 5 x | 6.5" |
| 5 x | 110 mm = | 5 x | 4.33" | 5 x | 120.65 mm = | 5 x | 4.75" | 5 x | 139.7 mm = | 5 x | 5.5" | 5 x | 205 mm = | 5 x | 8.07" |

COMMON LUG NUT STYLES

IMPORTANT: It is crucial that the lug nut seat and the wheel lug seat match. If the lug nut seat type does not match the wheel seat type, it is possible that the lug nut could damage the wheel, or possibly cause the lug nut to loosen and the wheel to become unsecure.



TAPERED SEAT

Also known as Acorn or conical wheel nut. They're a modern, OEM-style wheel nut that utilizes a tapered, cone-section on the end that matches the conical seat machined into the wheel's lug hole.

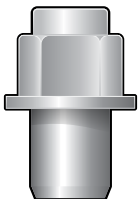

MAG SEAT

Also known as a flange nut. While often incorrectly used to describe a tapered seat, conical seat, or Acorn style wheel nut, Mag seat lug nuts can be identified by the long parallel shank section that extends into the wheel's center. This type of wheel nut is still commonly used on drag racing style wheels, as well as older-style mag wheels and must be used with a flat washer. Not to be used with wheels machined for tapered/conical seat wheel nuts.



FLAT SEAT

A fairly common type of lug nut that has a flat, washer-like seat.

⚠ SAFETY TIP: ⚠

Before you install your wheels, it is very important to check your vehicle's recommended torque specifications and make sure the lug nut is torqued correctly. If overtightened, both the lug nut and the stud can be fatigued, possibly leading to failure.

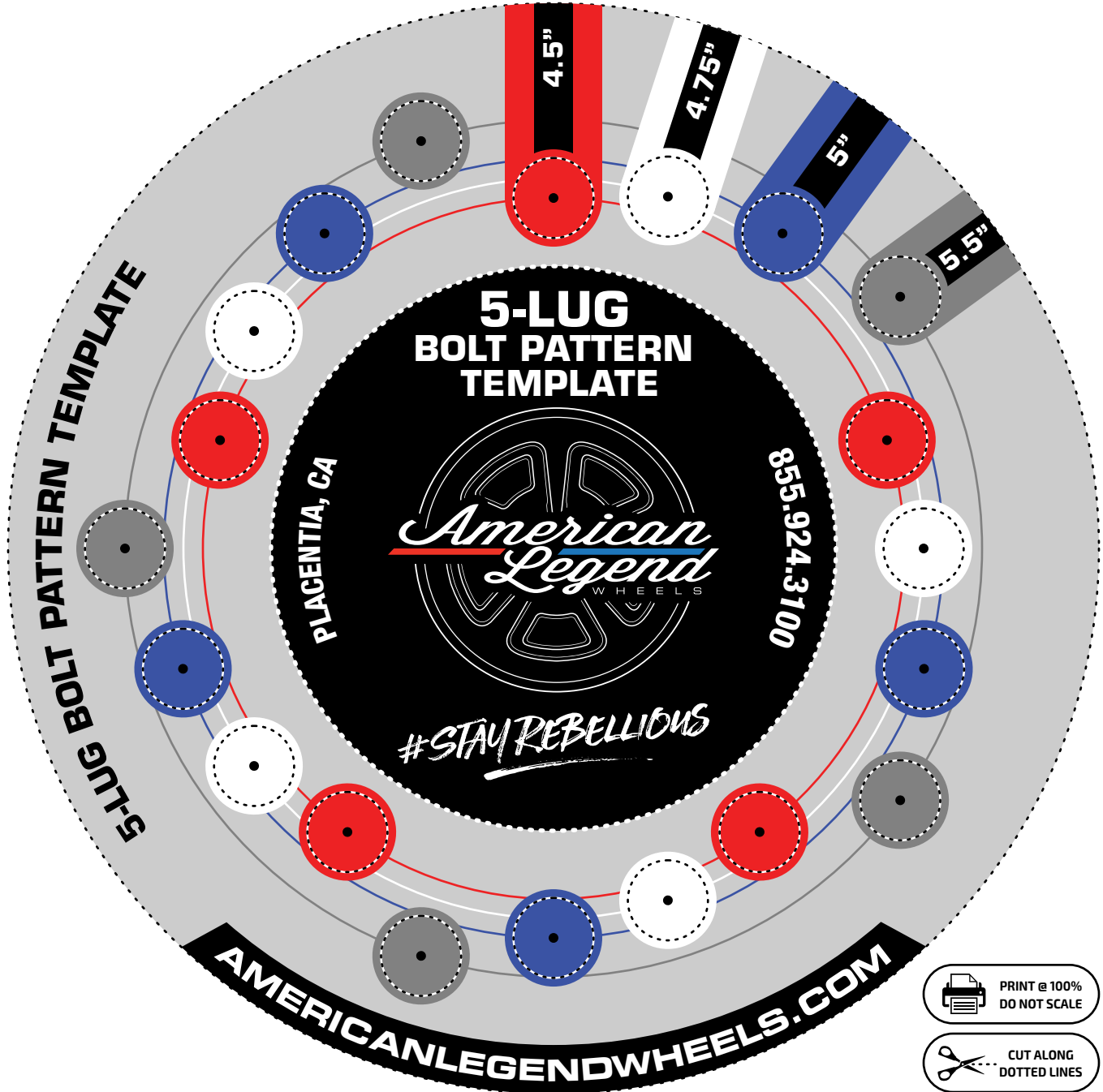

MEASURING BOLT PATTERNS

To measure 4, 6 and 8-lug bolt patterns, take your measurement from the middle of two wheel bolts directly across from one another. To measure 5-Lug patterns, take your measurement from the BACK of a wheel bolt to the CENTER of the SECOND wheel bolt. To accurately identify a 5-lug pattern, use the Bolt Pattern Template.

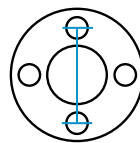

4-LUG

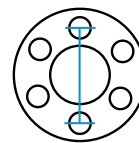

6-LUG

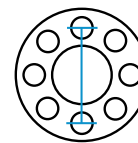

8-LUG

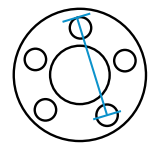

5-LUG

IMPORTANT: PRINT @ 100% SIZE - DO NOT SCALE IMAGE

To print to the Bolt Pattern Template the correct dimensions, you must ensure that the "Page Scaling" option in the print settings dialog box is set to "None" or 100%. Use the rule below to measure and verify the correct print size.

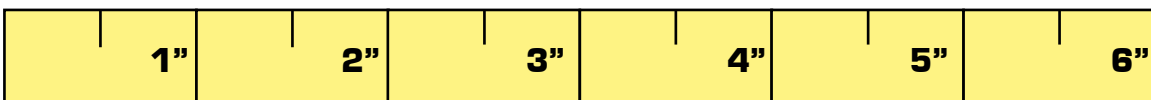



Classic Performance Products, Inc.

THE NEW HOME OF

American Legend
WHEELS

EXCITING NEWS! Classic Performance Products, Inc. (CPP)
Acquires American Legend Wheels

Classic Performance Products, Inc. is pleased to announce the acquisition of American Legend Wheels from Motoractive USA, the US subsidiary of Motoractive Australia. "We have known Jim Ries and his team for several years, this purchase becomes both a logical and valuable addition to his current automotive operations," said Bruce Morrison, President of Motoractive USA. "In the meantime, we would like to thank our customers - we have enjoyed serving you over many years and we know that Jim and the CPP team will take the American Legend business to new levels of excitement." Classic Performance Products, Inc. (CPP) has been serving the classic car and truck industry since 1991. A leader in steering, brakes and suspension, Classic Performance Products, Inc. is excited to add a wide offering of cast wheels to the classic car and truck market with the same goal in mind – high quality parts at an affordable price. "This was an easy decision for us," owner Jim Ries said. "There are so many wheel options in the market but we feel that American Legend Wheels had all the qualities we were looking to offer in style, fitment and finish." As of April 1, 2019, Classic Performance Products, Inc. is the new home of American Legend Wheels. Day to day operations and contact information will remain the same at this time.

Toll Free: (855) 924-3100 | Email: info@americanlegendwheels.com
378 E. Orangethorpe Ave. Placentia, CA 92870



THE NEW HOME OF AMERICAN LEGEND WHEELS

378 E. Orangethorpe Avenue
Placentia, CA 92870

AMERICANLEGENDWHEELS.COM

FOLLOW US!

#STAYREBELLIOUS